

TOWN OF LANGHAM

BYLAW NO. 2026-03

A BYLAW RESPECTING THE OPERATION OF LANGHAM CEMETERY

The Council of the Town of Langham, in the Province of Saskatchewan, enacts as follows:

1. This bylaw shall be known as the "Cemetery Bylaw."
2. In this Bylaw:
 - a) "Administrator" shall mean the Chief Administrative Officer of the Town of Langham or their designate.
 - b) "Public Works Foreman" means the person designated by the Town to oversee the operation and maintenance of the Cemetery or their designate.
 - c) "Block 1" means the section of the cemetery where the graves are 4' by 8' and have generally been set out in groups of 24 per lot, the use of which shall be as set forth in Schedule "C" annexed hereto and forming part of this Bylaw or as the Schedule "C" may be amended from time to time by Council Resolution.
 - d) "Block 2" means the section where the graves are 5' by 10' and have been set out in rows the use of which shall be as set forth in Schedule "C" annexed hereto and forming part of this Bylaw or as the Schedule "C" may be amended from time to time by Council Resolution.
 - e) "Cemetery" shall mean Langham Cemetery located in the North West $\frac{1}{4}$, section 21, Township 39, Range 7, West of the 3rd Meridian.
 - f) "Certificate for Use" shall mean a permit for the future use of a plot.
 - g) "Cremains" shall mean the ashes of a cremated human body.
 - h) "Plot" shall mean a parcel of land in the Cemetery for which a Certificate For Use may be purchased for the future interment of human remains or cremains.
 - i) "License" shall mean a permit provided by the Town to a holder of a Certificate For Use with respect to a plot for the purpose of each interment of human remains or cremains.
 - j) "Licensee" shall mean the holder, their heir, executor, or administrator of the Certificate For Use.

- k) "Monument" shall mean a tombstone or other structure in the Cemetery erected or constructed on any plot for memorial purposes.
- l) "Town" shall mean the Town of Langham.
- m) "Traditional Interment" shall mean the interment of the non-cremated human remains.
- n) "Columbarium" means a structure designed to contain niches for the placement of cremated human remains.
- o) "Niche" means an individual compartment within a columbarium for the interment of cremated remains.
- p) "Memorial Wall" means a structure or designated area within the Cemetery for the placement of commemorative plaques that do not contain human remains.
- q) "Memorial Wall Plaque" means a plaque installed on a Memorial Wall for commemorative purposes only and which does not confer any right of interment.

All other terms shall have the meaning as defined in "The Cemeteries Act."

3. **Plots and Niches**

- a) The Town may grant a Certificate For Use to any person for the exclusive use of a Plot or Columbarium niche. The said Certificate For Use shall be issued subject to all provisions of this Bylaw and any amendments thereto passed from time to time by Council. The fee for such Certificate For Use shall be in accordance with fees, rates, and charges as set forth in Schedule "A" annexed hereto and forming part of this Bylaw or as the Schedule "A" may be amended from time to time by Council Resolution. For the purposes of this Bylaw, a columbarium niche shall be deemed to be a burial plot for cremated human remains. The rights associated with columbarium niches shall be governed by Section 3 of this Bylaw.
- b) The License fee and all charges for work done or services rendered at Langham Cemetery shall be in accordance with the fees, rates, and charges as set forth in Schedule "A" annexed hereto and forming part of this Bylaw or as the Schedule "A" may be amended from time to time by Council Resolution.
- c) It shall be the responsibility of the Licensee to provide and maintain current contact information with the Town, including mailing address, telephone number, and, where available, email address. This requirement applies to all Certificates for Use, including graves, plots, and columbarium niches. The Town shall not be responsible for any failure of notice where contact information is outdated or incomplete.

d) No PLOT shall be used for any other purpose than for the burial of the human dead.

4. **Surrender of Certificate For Use**

- a) Every transfer of a Certificate for Use for a cemetery plot or columbarium niche subsequent to the original sale shall be made by the Licensee providing written notice to the Administrator. Such notice shall include a description of the plot or niche, the date of transfer, and the name and contact information of the transferee. Upon receipt of such notice and payment of the applicable fee as set out in Schedule "A", the Administrator shall record the transfer in the cemetery register and issue a new Certificate for Use to the transferee.
- b) Where all human remains have been removed from a plot, the plot shall be deemed unavailable and shall not be eligible for repurchase by the Town, except in accordance with applicable legislation.
- c) The Town may, but is not obligated to and at the discretion of the Administrator, repurchase a Certificate for Use where no interment has occurred. The repurchase amount and any applicable administrative fees shall be in accordance with Schedule "A". Where proof of the original purchase price cannot be provided, the Town may determine a reasonable repurchase value in accordance with Schedule "A".

5. **Interments and Disinterments**

- a) No person other than a qualified Funeral Director shall have charge of the interment or disinterment of a human body.
- b) No person other than the Public Works Foreman or a qualified Funeral Director shall have charge of the interment or disinterment of human cremains.
- c) A rough box only may be utilized in Block 1 but is not mandatory and fiberglass vaults must be utilized in Block 2 for all traditional interments.
- d) The opening and closing for all interments or disinterments shall be completed by the Town. The Town shall only insert licensee supplied fiberglass vault tops and only at the time of closing. The installation and insertion of all other vault types shall be the responsibility of the licensee.
- e) All fees for opening and closing shall be in accordance with Schedule "A" annexed hereto and forming part of this Bylaw or as the Schedule "A" may be amended from time to time by Council Resolutions. Fees are

payable to the Town by the Licensee or their legal representative and are due at the time of License application and shall be deemed to be in arrears 30 days after that date.

- f) At least forty-eight (48) hours notice (during normal office hours) shall be given to the Public Works Foreman before the proposed time of interment, if proper notice is not given there may be an extra fee charged. This provision as to notice shall not apply in the case of interment of a person who has died from a communicable disease.
- g) Graves for Traditional Interments shall be at least six (6) feet in depth from the surface of the ground surrounding the Grave. No casket burial shall be permitted in a plot where cremains have been buried.
- h) Graves for cremated remains shall be at least thirty inches (30) in depth from the surface of the ground surrounding the Grave.
- i) Disinterment shall only be permitted upon the production of the written permission of the Minister of Public Health issued pursuant to an application under the Public Health Act, and upon the payment of the appropriate fee as set out in Schedule "A" annexed hereto and forming part of this Bylaw or as the Schedule "A" may be amended from time to time by Council Resolution.
- j) No disinterment shall be carried out between November 1 and March 31 unless authorized by the Attorney General of the Province of Saskatchewan. The proposed time of disinterment shall, subject to the provisions of any order of the Minister of Public Health or the Attorney General of the Province, be subject to the consent of the Public Works Foreman.
- k) Prior to any interment, any person arranging for the interment in any Grave in the Cemetery shall provide the following to the Town:
 - i) A Burial Permit issued by the properly authorized officer of the Provincial Government;
 - ii) In the case of Cremains, a copy of the cremation certificate issued by the crematorium; and
 - iii) An application for a License completed with the necessary information and signed by the Licensee or their legal representative and accompanied with the Certificate for Use.
- l) After hours, weekend and holiday interments are subject to extra charges as set out in Schedule "A" in addition to any other fees

- i) The Town may postpone any interment in the event of severe weather that makes the Cemetery impassable and ties up Town equipment.

6. **Indigent Burials**

- a) At the request of the Minister of Social Services or the Minister of Public Health, the Town shall provide Graves without charge for the interment of indigent persons.

7. **Care and Improvement of Graves**

- a) Notwithstanding the provisions of this section, the placement, maintenance, and regulation of monuments and columbarium niches shall be governed by Schedules "B", "C" and "D" respectively.
- b) All graves lots in the cemeteries shall be entitled to basic maintenance and care which includes leveling of the ground and the seeding and cutting of grass as required. It shall not include the maintenance, repair or replacements of monuments or markers.
- c) No person shall place any trees, flowers, shrubs, or similar plant material intended for growth on any Grave in the Cemetery except as permitted under Schedules "B" and "D". Any such trees, flowers, or similar plant material situated on or adjacent to any plot or part thereof that are, in the opinion of the Public Works Foreman, detrimental to any adjacent Grave, path or roadway or to the general appearance of the Cemetery or become dangerous or inconvenient to the public, or hinder the normal maintenance of the Cemetery may be ordered removed by the Public Works Foreman.
- d) No person shall construct any fence, railing, trellis, coping, or concrete cover on any grave in the Cemetery.
- e) Should any fence, railing, trellis, coping, border, tree, shrub, or hedge erected before passing of this Bylaw be in a state of disrepair or become offensive or is encroaching on adjacent graves, roadway, or walkway, or hinder the routine maintenance of the Cemetery, the Public Works Foreman may order the removal of same. The Public Works Foreman shall give notice in writing to the Licensee at his last known address for service. If the Licensee is unable to be notified at the last known address or where no address is available, the Public Works Foreman may proceed with the removal without further notice.
- f) Natural or artificial flowers shall be permitted in holders, vases, or other

unbreakable receptacles as set out in Schedule "B" or in designated areas as permitted under Schedule "D".

- g) No person shall place or maintain on any grave any glass encased designs, stands, holders, vases, or other objects made of glass.
- h) In order to preserve the proper appearance of the grounds, the Public Works Foreman shall have the authority to remove any article placed on any Grave or columbarium structure when the article is considered objectionable or its removal is deemed necessary by the Public Works Foreman. When the Public Works Foreman considers the removed article to be of value, the Public Works Foreman shall forward a written notice to the Licensee at his last known address, notifying him of the removal of the article and that such article may be claimed within thirty (30) days of the date of the notice. Where no claim is made to the Public Works Foreman after the expiry of thirty (30) days or where no notice can be given, the Public Works Foreman shall dispose of the article.
- i) The Town shall remove all grave covers which are in a state of disrepair or in need of lifting due to the grave has settled. No repair to grave covers will be allowed.
- j) The Town reserves the right to remove all grave covers, regardless of condition. No grave cover, shall be removed from the Cemetery without first applying for and receiving approval from the Administrator by submitting a Concrete Cover Removal application form.
- k) When the Town removes a grave cover, the Town shall relocate any existing monument (and base) to a new monument pad constructed by the Town. If feasible, the location of the monument pad shall be in accordance with the requirement set forth in Schedule "B" annexed hereto and forming part of the Bylaw or as Schedule "B" may be amended from time to time by Council Resolution.

8. Cemetery Fund

- a) The Town shall establish and maintain a Cemetery Fund in accordance with the provisions of The Cemeteries Act.
- b) A care and maintenance contribution shall be collected in addition to all other applicable fees and charges for each sale of a plot or columbarium niche in accordance with Schedule "A" annexed hereto and forming part of this Bylaw or as Schedule "A" may be amended from time to time by Council resolution.
- c) Income earned from the Cemetery Fund may be used for the care, maintenance, and improvement of the Cemetery, including the maintenance of columbarium structures and cemetery grounds.

9. Recovery of unused burial Plots

- d) Pursuant to the provisions of *The Cemeteries Act* where a burial plot has been sold and no interment has taken place, the Town may recover the unused burial plot in accordance with the Act.
- e) Where the owner of record cannot be located or where ownership has been abandoned, the Town may, after providing notice in accordance with *The Cemeteries Act* declare the plot forfeited and return it to the Town's inventory for resale.
- f) Where a burial plot has not been used for interment purposes, and the owner of the cemetery has not had any communication from the purchaser or the purchaser's personal representative for a period of at least twenty (20) years, the Town may, after providing notice in accordance with *The Cemeteries Act* declare the plot forfeited and return it to the Town's inventory for resale.
- g) Upon recovery of a burial plot under this section, all rights and interests of the former owner shall cease, and the Town shall update its cemetery records accordingly.
- h) The Town shall comply with all record-keeping, refund, and trust fund requirements as required by provincial legislation.
- i) Where a burial plot or columbarium niche has been recovered by the Town in accordance with this Bylaw and applicable legislation, and a person subsequently provides satisfactory proof of prior ownership, the Town may, at its discretion, grant that person a Certificate for Use for a comparable plot or niche, subject to availability. The Town shall not be obligated to provide the same location or block as originally held.

10. Columbarium

- a) The Town may establish, operate, and maintain one or more columbarium's within the municipal cemetery.
- b) The Town may establish, operate, and maintain memorial wall plaques within the cemetery for commemorative purposes.
 - 1) Memorial wall plaques do not confer any right of interment.
- c) All columbarium niches shall be sold, administered, and regulated in accordance with this Bylaw and *The Cemeteries Act*.
- d) The purchase of a columbarium niche grants the purchaser the exclusive right of interment within the niche but does not convey ownership of land.
- e) No interment shall take place until all required fees have been paid in full.

- 1) All fees related to the purchase, interment, inscription, transfer, or other services related to columbarium niches shall be as set out in Schedule "A" annexed hereto.
 - 2) No interment of cremated remains in a niche shall occur without a valid License issued by the Town.
- f) Only cremated human remains may be placed in a columbarium niche.
 - g) A care and maintenance contribution shall be collected in accordance with provincial legislation at the time of purchase and administered as required by law.
 - h) The Town shall be responsible for maintaining the structure of the columbarium but shall not be responsible for damage to urns or personal items placed within a niche.
 - i) All niche fronts, plaques, and inscriptions shall conform to the Town's approved columbarium specifications as set out in Schedule "D".
 - j) No decorations, ornaments, or other items shall be affixed to or placed upon a columbarium except as permitted under Schedule "D".
 - k) All transfers shall be subject to submission of a written request to the Administrator and payment of the applicable fee as set out in Schedule "A".
 - l) Unused niches may be surrendered to the Town subject to the refund provisions and legislative requirements of provincial legislation.
 - m) Where a niche remains unused and meets the abandonment or forfeiture conditions set out in this Bylaw and provincial legislation, the Town may recover the niche in accordance with the notice requirements prescribed by law.
 - n) The operation, use, and regulation of columbarium niches and memorial wall plaques shall be in accordance with Schedule "D".

11. **Monuments and Markers**

- a) No Monument/Marker, or object of any kind shall be placed on any grave in the Cemetery except as provided for in this Section and as set out in Schedule "B" annexed hereto and forming part of this Bylaw or as the Schedule "B" may be amended from time to time by Council Resolution.
- b) No Monument/Marker shall be erected in or removed from the Cemetery without first applying for and receiving approval from the Administrator by submitting a Monument/Marker application form. No approval shall be given until all fees have been paid.
- c) All Monument/Marker installations and the cost thereof shall be the

responsibility of the Licensee.

- d) Foot markers, corner markers and other such markers shall not be installed in any part of the Cemetery.

12. **Veterans Section**

- a) The Town has set aside and shall maintain a portion of the Cemetery as a Veteran's Section for the placement of Memorial Crosses. Memorial Crosses shall only be placed for those Veterans who had enlisted in Langham and the Park Municipality and whose names appear on the Langham Legion Honour roll.

13. **General**

- a) Children under the age of (14) shall not be permitted in the Cemetery unless accompanied by an adult who shall be responsible for their proper conduct.
- b) No dogs or other pets shall be allowed in the Cemetery.
- c) Sports activities of any kind and the equipment used for sporting activities shall not be allowed in the Cemetery.
- d) No person shall discharge any firearms in the Cemetery except by special permission given by the Public Works Foreman.
- e) No Person shall unlawfully disturb persons assembled for the burial of the dead, or commit a nuisance, or behave in an indecent or unseemly manner in the cemetery.
- f) All persons undertaking any work in the Cemetery shall comply with all orders of the Public Works Foreman and shall cease work when a burial is taking place in the vicinity of the work.
- g) Any notice given pursuant to this Bylaw shall be deemed sufficient if sent to the last contact information provided to the Town by the Licensee. The Town shall not be responsible for any failure of notice where contact information is outdated or incomplete.
- h) Situations that are not specifically covered by this Bylaw shall be dealt with at the discretion of the Public Works Foreman in conjunction with the Administrator. The Administrator may delegate any duties assigned under this Bylaw.
- i) This Bylaw shall come into force on the day of its final passing.

14. **Infractions of the Bylaw**

Any person who contravenes the provisions of this Bylaw or fails to comply herewith, or with any notice given hereunder, is guilty of an offence and liable to a penalty of:

- a) not less than \$100 and not more than \$2,000 in the case of an individual; and
- b) not less than \$200 and not more than \$5,000 in the case of a corporation.

15. **Repeals**

Bylaw No. 2019-02 is hereby repealed.

READ A FIRST TIME THIS 6th day of April, 2026

READ A SECOND TIME THIS 6th day of April, 2026

READ A THIRD TIME AND PASSED THIS 27th day of April, 2026

MAYOR

ADMINISTRATOR

**TOWN OF LANGHAM
SCHEDULE "A"
TO BYLAW NO. 2026-03**

LANGHAM CEMETERY FEES

PLOTS AND INTERMENTS

The following costs will be billed by the Town of Langham

Certificate For Use Fee	Plots	\$750
	Columbarium Niche	\$2000

Cemetery Fund Contribution	\$250
<small>(applies to all plot and columbarium niche purchases; charged in addition to purchase price)</small>	

License for Burial Fees

April 1 to October 31

Traditional Burial	
Opening/Closing	\$1000
Cremaains	\$400
Opening/Closing	
Columbarium	\$150
Opening/Closing	

November 1 to March 31

Traditional Burial	
Opening/Closing	\$1400
Cremaains	\$600
Opening/Closing	
Columbarium	\$150
Opening/Closing	

Weekend, Holidays, After Hours Open/Close

Evenings, Saturdays, Sundays & Holidays	Additional
Including: after 4 pm from April 1 to October 31; and after 3 pm from November 1 to March 31	
Traditional Burial/ Cremaains	\$400
Opening/Closing	
Columbarium	\$100
Opening/Closing	

Exhumations

Traditional Human remains Opening/closing	\$1400
Cremains Opening/closing	\$600
Columbarium Opening/closing	\$150

Monuments/Markers

Monument/Marker Application Fee	\$50
----------------------------------------	------

Licensee is responsible for all Monument costs. See Schedule "B" for Monument Policy and Schedule C for grave use Policy.

In Block 2 the monument pad will be supplied by the Town of Langham.

Should a monument be required to be moved to accommodate an opening, all such costs will be the responsibility of the Licensee

Columbarium and Memorial Plaques

Columbarium Plaque	Included in Niche Price
Future Date Plaque	Included in Niche Price
Replacement or Revised Plaque	Cost plus \$50 Admin Fee
Memory Wall Plaque	\$500

Certificate Transfers and Buy Backs

Transfer Fee (per plot or niche)	\$50
Buy-Back of Certificate for Use (No Interment)	Original purchase price less a 25% administrative fee (minimum \$50)
Buy-Back (no proof of purchase)	\$50

**TOWN OF LANGHAM
SCHEDULE "B"
TO BYLAW NO. 2026-03**

LANGHAM CEMETERY MONUMENT POLICY

General

All monuments and installations thereof must be in accordance with this schedule.

No Monument/Marker shall be erected in or removed from the Cemetery with out first applying for and receiving approval from the Administrator by submitting a Monument/Marker application form. No approval shall be given until all fees have been paid.

There shall be no more than one monument per grave.

Flat grass markers installed at grade will be allowed for marking cremains burials or for memorial where burial has been elsewhere. Markers will only be allowed over cremains locations as specified in Schedule C of the Cemetery Bylaw.

No concrete grave covers will be permitted except as allowed for by Section 7 (b) of the Cemetery Bylaw.

The licensee of a grave or graves will be the authority in regards to the placement of a monument on a grave or graves. The Town does not accept any responsibility for resolving disputes between surviving family members or friends resulting from the placement of a monument.

Monuments and Flat Grass Markers are placed in the Cemetery at the risk of the licensee of the grave or graves. The Town accepts no responsibility for theft or damage resulting from vandalism or Cemetery maintenance.

Monument Installation Timing

No monument or marker shall be installed on a plot in Block 1 until all intended interments within that plot have been completed.

Where a monument or marker is installed prior to all interments being completed, the Licensee shall be responsible for all costs associated with the removal, storage, and reinstallation of the monument to facilitate future interments.

The Town shall not be responsible for any damage to monuments or markers that must be moved or disturbed to allow for the opening of a grave.

Installation Specifications

All monument installation and the cost thereof shall be the responsibility of the Licensee. Monument installation in Block 1 shall include the cost and installation of a 127 cm (4 ft 2 in) by 60 cm (2 ft.) monument pad installed on the western 60 cm (2 ft) of

the grave involved. Monument installation in Block 2 shall be on the monument pads provided for by the Town.

All monuments shall be of granite, bronze, marble, or stone and have a minimum thickness of 10cm (4 in.)

The sides of the base (excluding the top and bottom) must have a rock-pitch finish. Any base with a minimum height of 15 cm (6 in.) will be permitted a sawn or polished margin. The margin must be made so that a minimum of 10 cm (4 in.) on the bottom of each side is left as a rock-pitch finish. A monument without a base must have at least 10 cm (4 in.) on the bottom of each side left as a rock-pitch finish.

All bases (or monuments without bases) are subject to the following:

- (a) the maximum width of a base shall be 45 cm (18 in.);
- (b) the maximum length of a base shall be 15 cm (6 in.) less than the width of the monument pad.
- (c) The minimum height of a base shall be 10 cm (4in).

All dies are subject to the following;

- (a) the overall length and width dimensions (including any fixtures) will not exceed the length and width of the base.

Flat grass markers for cremains burials are subject to the following;

- (a) the minimum thickness shall be 8cm (3 in.);
- (b) the maximum length shall be 40 cm (16 in.);
- (c) the maximum width shall be 35 cm (14 in.).

Total monument height will not exceed 90 cm (36 in.).

Any monument assembly erected must have the base and die joined, front and back, by use of a non-permanent setting compound. Monuments cannot be permanently attached or pinned to the concrete pad.

All vases must be permanently affixed and positioned so that no part extends beyond the length or width of the base nor extends above the total monument height. Marble or granite vases will be restricted to a minimum thickness of 2.5cm (1in.) at any point.

Non-Compliant Monuments

Any monument or marker installed in the Cemetery that does not comply with this Bylaw or Schedule "B", including but not limited to size, material, placement, or installation requirements, may be refused, removed, or required to be corrected by the Town.

The Licensee shall be responsible for all costs associated with the removal, correction, or reinstallation of any non-compliant monument or marker.

Where monument or marker is installed without approval, the Town may remove the monument without notice. The Town shall not be responsible for any damage to monuments that are removed or handled due to non-compliance with this Bylaw.

**TOWN OF LANGHAM
SCHEDULE "C"
TO BYLAW NO. 2026-03**

LANGHAM CEMETERY GRAVE USE POLICY

Block 1

A maximum of one casket burial and 2 cremains burials will be allowed per plot subject to the following;

Casket burials will be allowed only when there is a full 4'2" x 8' space available.

No casket burial will be allowed if there has been a previous cremains burial.

No cremains burial will be allowed where there is concrete grave cover.

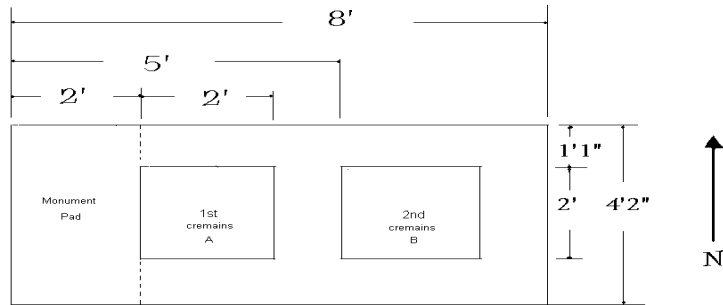

Note: A physical inspection may be required in Block 1 to determine if cremains can be allowed. (Monument location? Encroachment?)

Block 2

A maximum of one casket burial and 3 cremains burials will be allowed per plot.

No casket burials will be allowed if there has been a previous cremains burial.

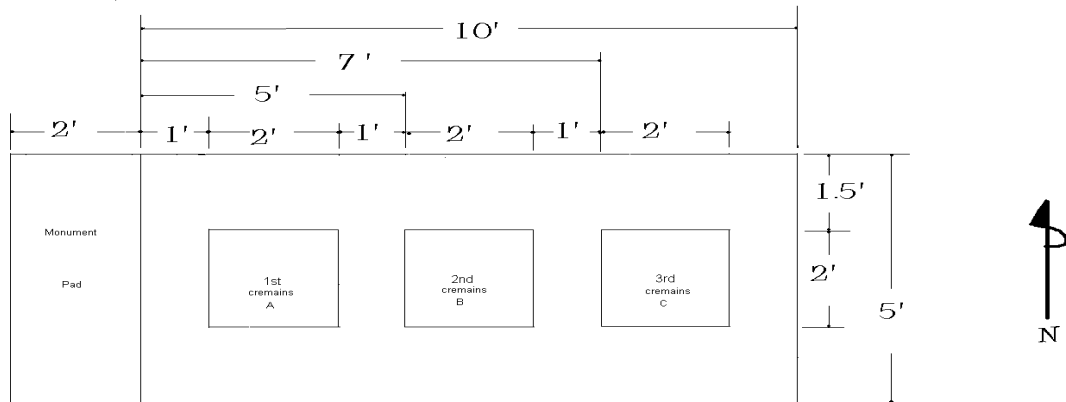

**TOWN OF LANGHAM
SCHEDULE "D"
TO BYLAW NO. 2026-03**

LANGHAM CEMETERY COLUMBARIUM POLICY

All columbarium niches, memory wall plaques, and installations thereof must be in accordance with this Schedule.

Columbarium Niches

No niche shall be used for any purpose other than the interment of cremated human remains.

A maximum of two (2) urns may be placed in a niche, provided both urns fit within the niche and do not interfere with the proper closing of the niche.

All openings and closings of niches shall be completed by the Town of Langham or its authorized contractor.

No person shall open, close, or otherwise interfere with a niche.

Plaques – Columbarium

All niche plaques shall be supplied through the Town's approved bronze plaque program.

No plaque shall be installed, altered, or replaced except by the Town or its approved supplier.

No substitute plaque styles or materials shall be permitted unless approved by the Administrator.

All plaques shall be uniform in size, material, and design as determined by the Town.

All inscription wording shall be subject to approval by the Administrator.

The Town reserves the right to refuse any inscription that is deemed inappropriate or inconsistent with the approved plaque program.

Where a niche is sold pre-need, the plaque may be ordered with the approved name and date of birth, and the date of passing shall be added at a later time.

Any replacement or revision of a plaque shall be at the cost of the Licensee in accordance with Schedule "A".

Memory Wall Plaques

Memory wall plaques shall only be installed in locations designated by the Town.

All memory wall plaques shall be supplied through the Town's approved supplier and shall be uniform in design and material.

No plaque shall be installed, altered, or removed except by the Town or its approved supplier.

Memory wall plaques are memorial only and do not provide any right of interment.

All inscription wording shall be subject to approval by the Administrator.

The Town reserves the right to refuse any inscription that is deemed inappropriate or inconsistent with the approved memorial program.

Decorations

No person shall affix any decoration, ornament, or other object to a columbarium niche or memory wall plaque.

Flowers or decorations shall only be placed in areas designated by the Town.

The Town may remove any decoration or item that is, in the opinion of the Public Works Foreman:

- unsafe
- unsightly
- deteriorated
- interfering with maintenance

The Town shall not be responsible for any loss or damage to decorations or personal items.

Care and Maintenance

The Town shall maintain the columbarium structure and surrounding grounds.

The Town shall not be responsible for damage to plaques or memorial items except where caused by the Town.

The Town reserves the right to restrict access to the columbarium or memory wall areas for maintenance or repair.

Installation and Supplier Requirements

All plaques shall be ordered through the Town.

No private installation of plaques or memorial items shall be permitted.

The columbarium has been designed for a specific plaque system, and all plaques must be compatible with that system.

General

All requests for inurnment, plaques, inscriptions, or changes shall be made through the Town office.

All fees related to columbarium niches, plaques, and services shall be as set out in Schedule "A".